

ISLAND AND HORIZONTAL



VELDEN LX



A
R
N
E
G



ATTRACTIVE, SEDUCTIVE PRESENTATION.

The result of an advanced display concept aimed at stimulating the Grab&Go purchases typical of modern shopping, the new Velden LX range of semi-vertical cabinets and islands places the product centre-stage. Latest-generation LX design, great versatility and maximum functionality for an unprecedented shopping experience.

LX DESIGN: QUALITY TAKES THE STAGE.

Clean, linear and lightweight forms enhance visibility and focus attention on the freshness of the foods. This new design also ensures a uniform look with other Arneg LX cabinets.



SPACE FOR VERSATILITY.



The transparency and essential design of the semi-vertical version, with or without end units, guarantees exceptional visibility while the island version offers an all-round view. Thanks to its double basin, Velden LX can display a wide range of products, from pre-packed dairy, cold cuts and fruit and veg to delicate foods like meat, pre-packed fish, desserts and cold deli.

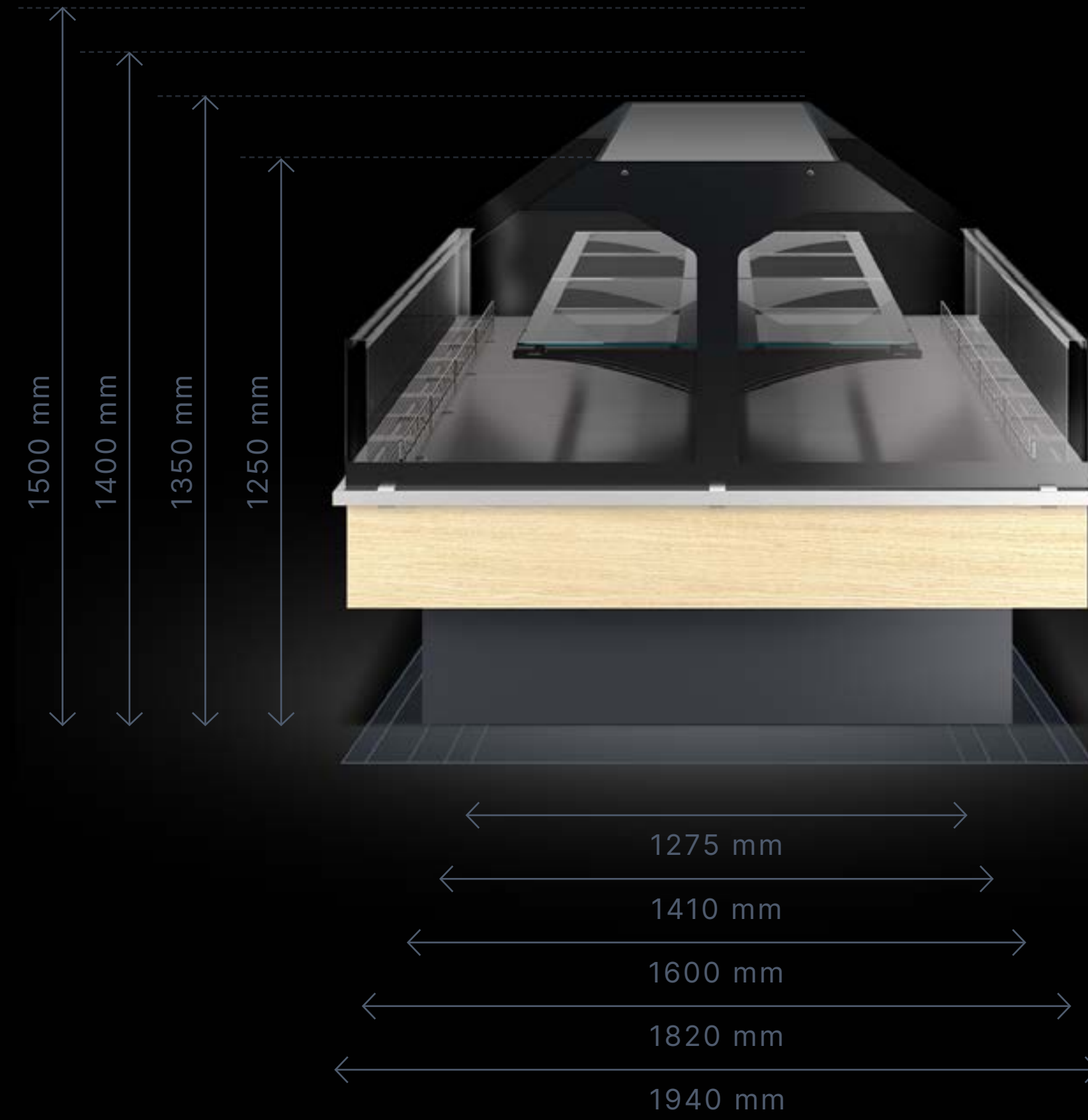
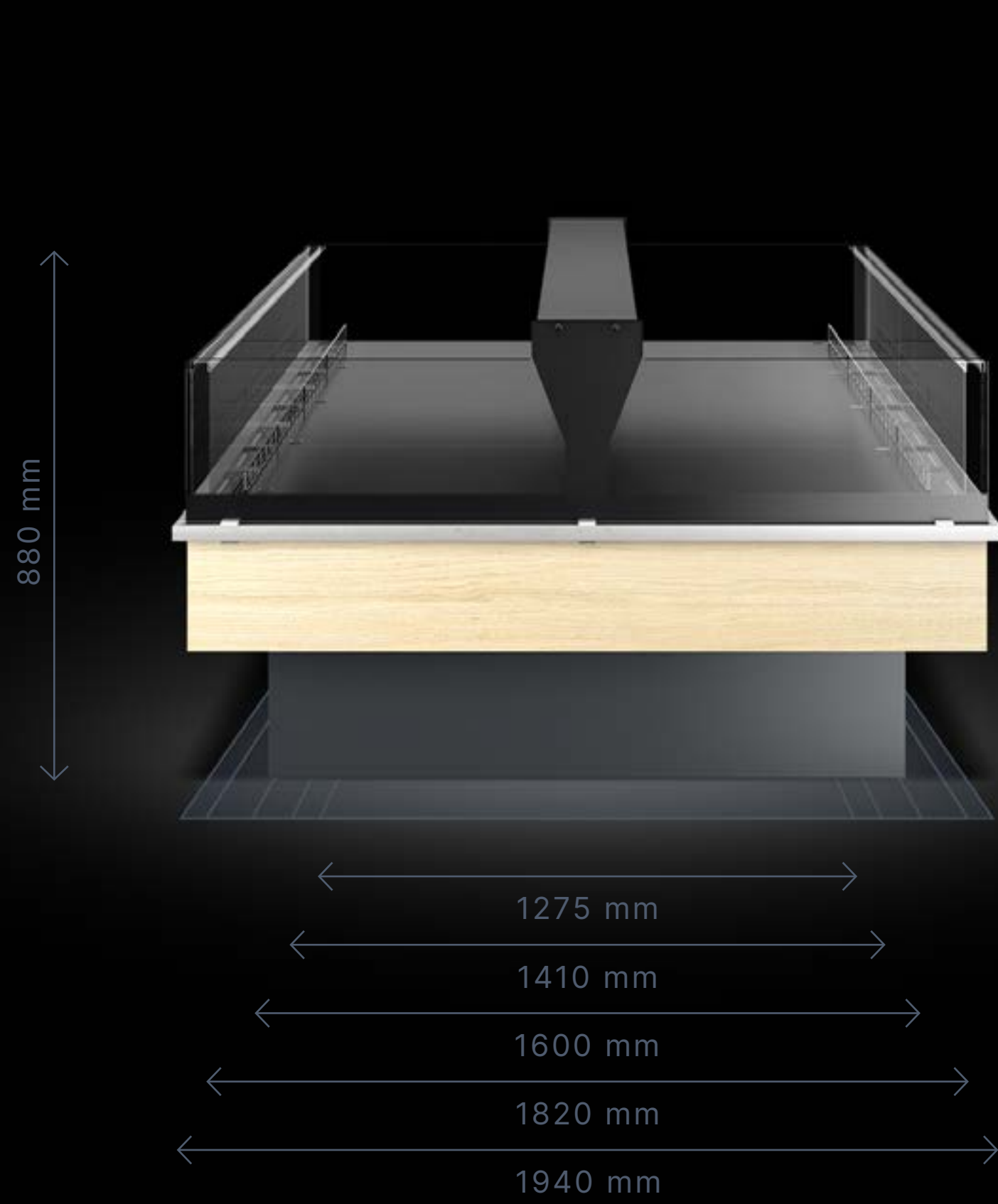

- Minimalist design
- Maximum transparency
- Integrated LED lighting option
- Double basin structure
- High load capacity
- Easy access to products



PERFECT IN ANY SETTING.

Remote, multiplexable and available in various depths and heights, the Velden LX range can be customised in finish to match the décor of any store.

- laminates
- stainless steel
- paint finishes





1



2

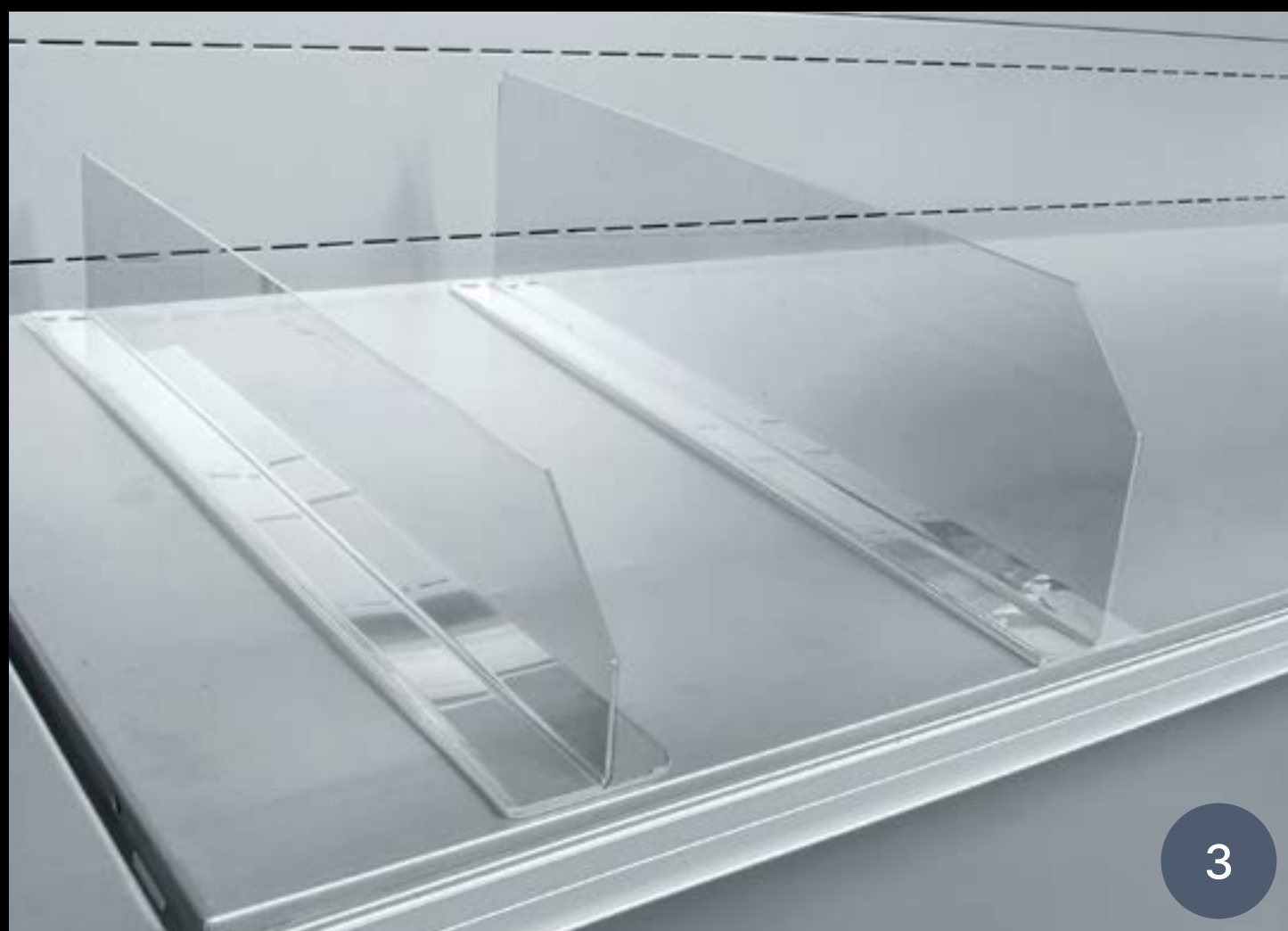

3



4

ACCESSORIES

- 1 - H32 price-holder for IMZ shelf
- 2 - H25 price-holder for IMZ shelf
- 3 - Plexiglass partitions
- 4 - Clear price holder for IMZ shelf



5

5 - 12 mm glass shelf



7

6 - Ultra-slim 15 mm shelf

7 - Wire fence



6



6

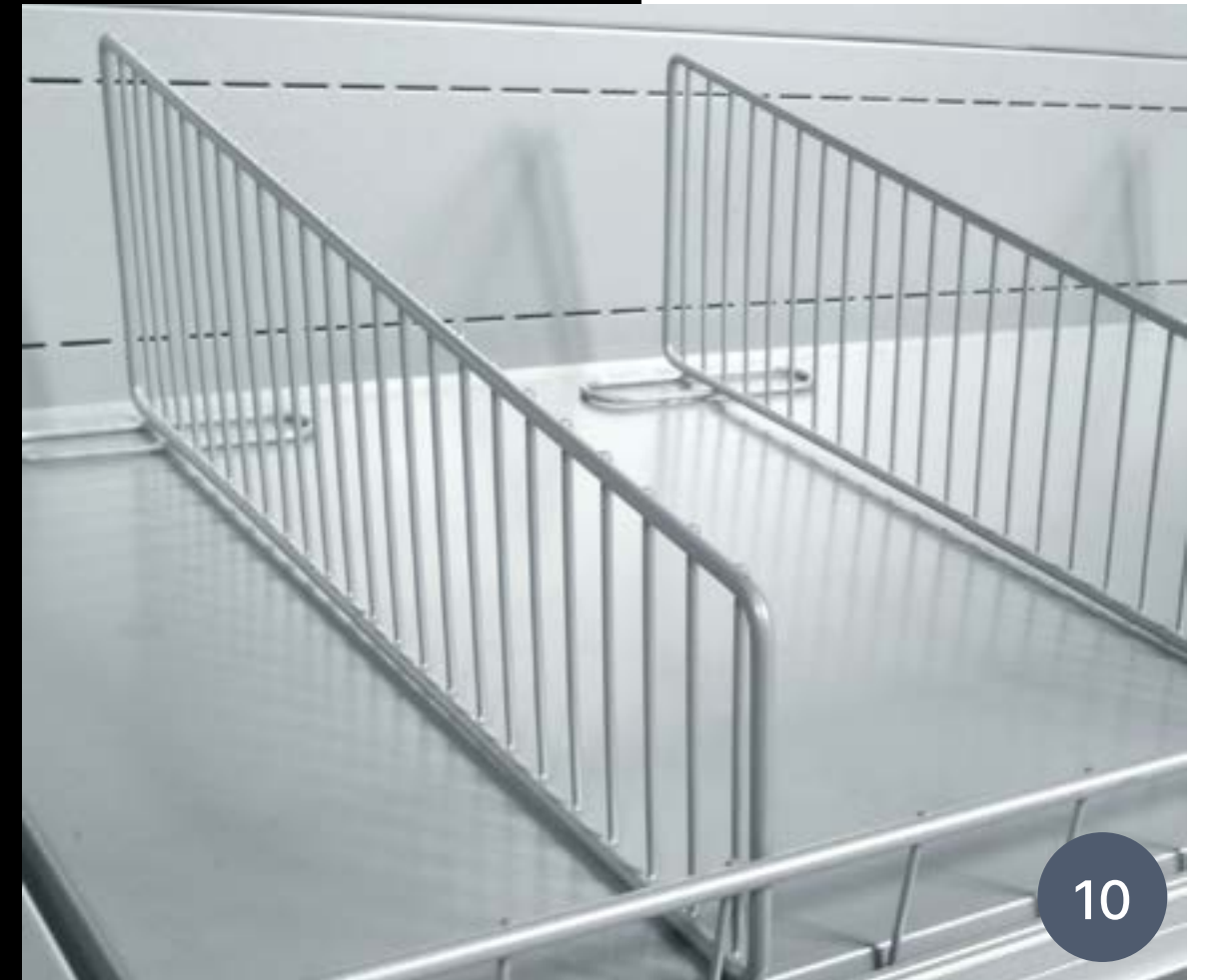

8 - Rectangular bumper

9 - Clear shelf

10 - Wire basin partitions

11 - Wire shelf

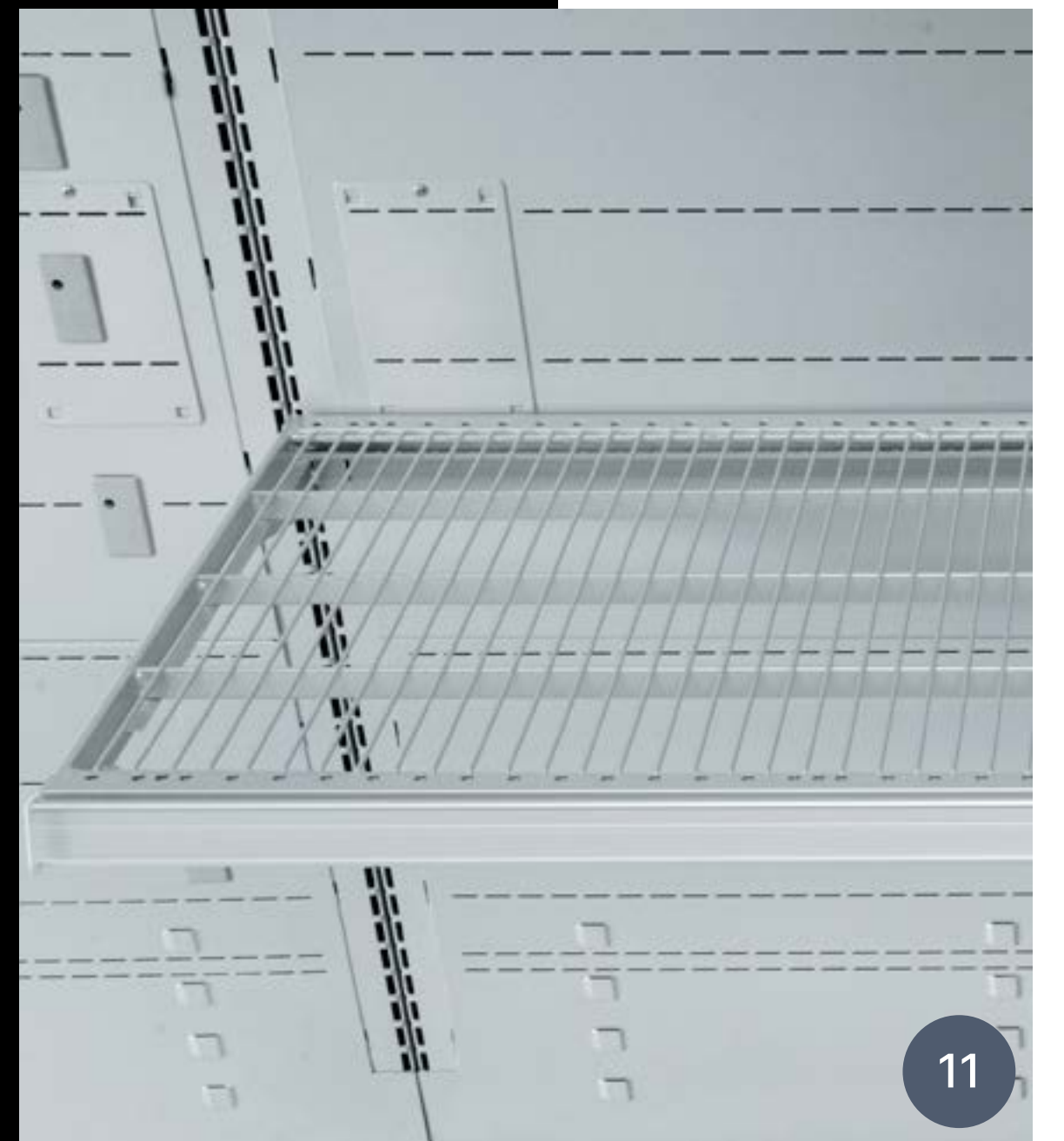



12

12 - Plexiglass fence

13 - Bar price holder
for IMZ shelf

14 - Manual night blind



13



14

VELDEN LX ISL-A-2 TN V LINEARE R

Length without side panels (mm)		1250	1875	2500	3750
Temperature class	3M1	•	•	•	•
	3M2	•	•	•	•
Preservation temperature (°C)	0/+2	•	•	•	•
	+2/+4	•	•	•	•
Horizontal display area* (m ²)	Depth 130	1,2	1,8	2,4	3,6
	140	1,38	2,06	2,75	4,13
	160	1,6	2,4	3,2	4,8
	180	1,88	2,81	3,75	5,63
	194	2,03	3,04	4,05	6,08
Energy class**	Depth 130 - 140	A + G F	A + G F	A + G F	A + G F
	- 160 - 180				
	- 194				

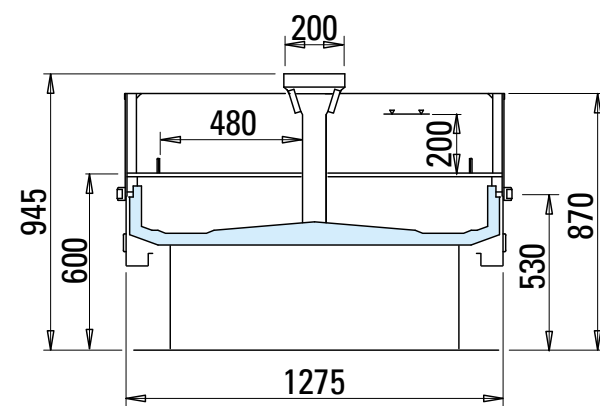

130

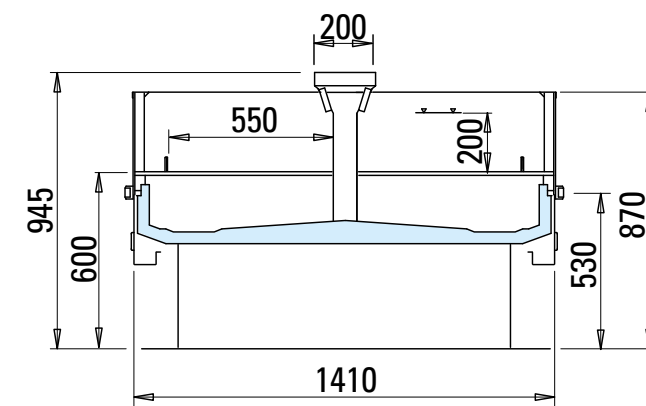

140

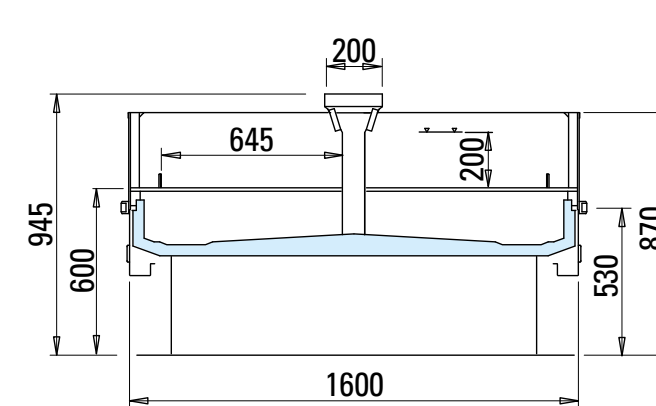

160

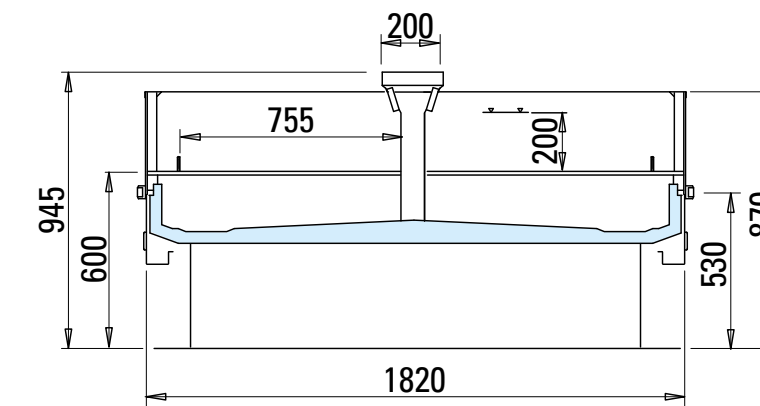



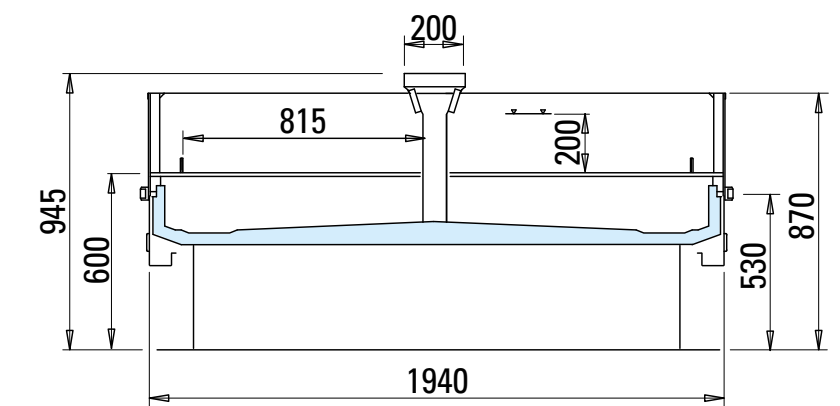

180

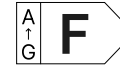

194

VELDEN LX ISL-A-2 TN V TESTATA R

Length without side panels (mm)		1284	1419	1610	1832	1952
Temperature class	3M1	•	•	•	•	•
	3M2	•	•	•	•	•
Preservation temperature (°C)	0/+2	•	•	•	•	•
	+2/+4	•	•	•	•	•
Horizontal display area* (m²)		0,77	0,68	0,99	1,13	1,21
Energy class**						

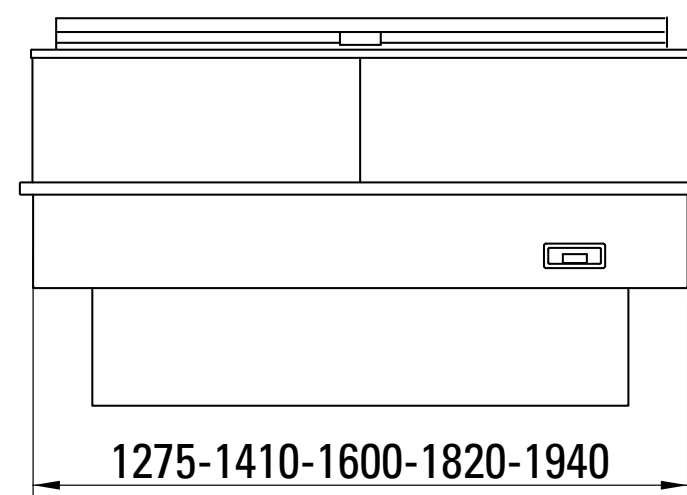

-

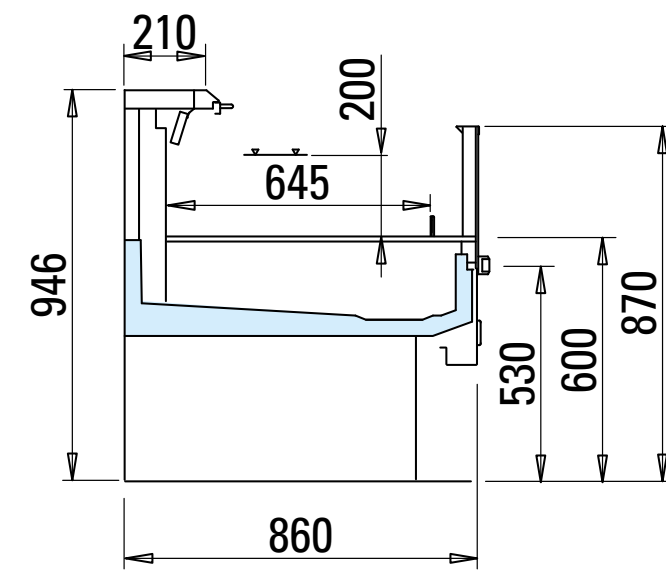

130

VELDEN LX SVT-A-2 TN V LINEARE R

Length without side panels (mm)	1250				1875				2500				3750				
Height	125	135	140	150	125	135	140	150	125	135	140	150	125	135	140	150	
Temperature class	3M1	•	•	•	•	•	•	•	•	•	•	•	•	•	•	•	•
	3M2	•	•	•	•	•	•	•	•	•	•	•	•	•	•	•	•
Preservation temperature (°C)	0/+2	•	•	•	•	•	•	•	•	•	•	•	•	•	•	•	•
	+2/+4	•	•	•	•	•	•	•	•	•	•	•	•	•	•	•	•
Horizontal display area* (m²)	Depth	130	-	-	2,58	2,93	3,86	-	3,86	3,9	5,15	-	5,15	5,58	7,73	-	7,73
		140	-	-	-	3,19	-	4,13	-	4,25	-	5,5	-	6,38	-	8,25	-
		160	2,6	-	3,35	-	3,9	-	5,03	-	5,2	-	6,7	-	7,8	-	10,25
		180	-	-	-	4,31	5,44	-	5,44	5,75	7,25	-	7,25	8,63	10,88	-	10,88
		194	3,28	-	-	4,91	6,41	-	6,55	8,55	9,83	-	12,83	-	-	-	-
Energy class**	Depth	130	-	-	F	F	-	F	F	-	F	F	-	F	-	F	
		140	-	-	-	F	-	F	-	F	-	F	-	F	-	F	
		160	-	F	-	-	F	-	-	F	-	-	F	-	-	F	
		180	-	-	-	F	-	F	-	F	-	F	-	F	-	F	
		194	F	-	-	-	F	-	-	F	-	-	F	-	-	F	

*Value referred to illustrated configurations. **The energy class may vary depending on the product configuration.

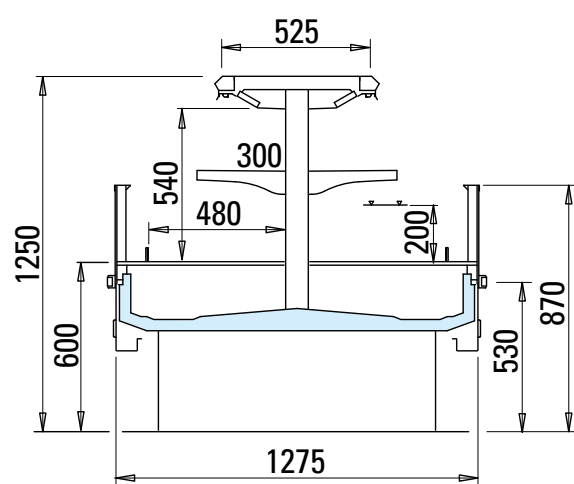

130 H125

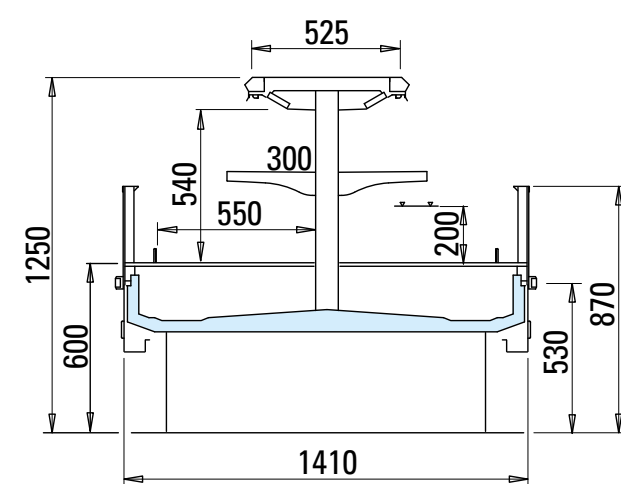

140 H125

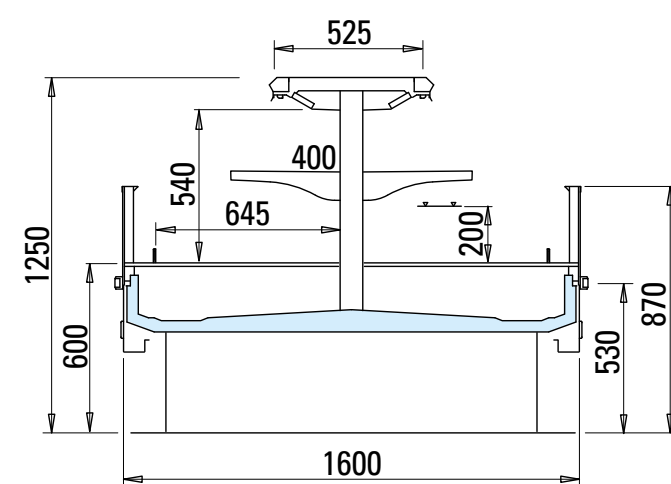

160 H125

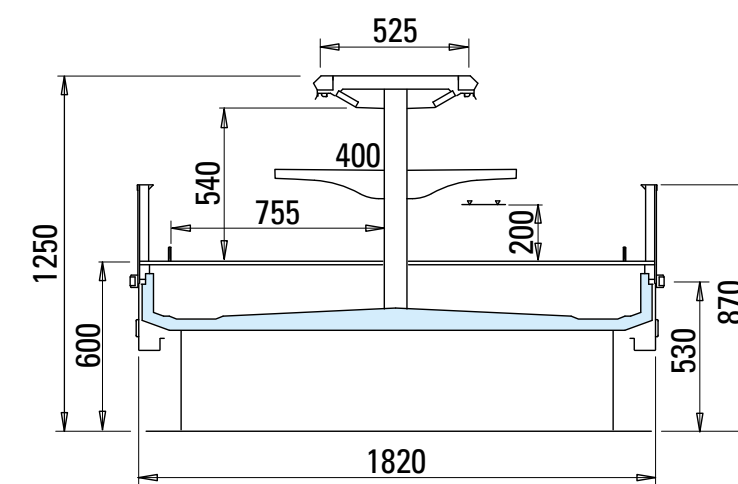

180 H125

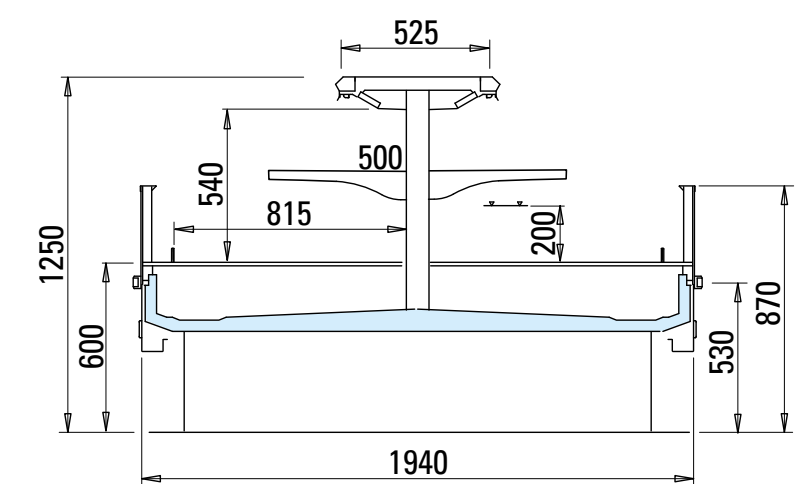

194 H125

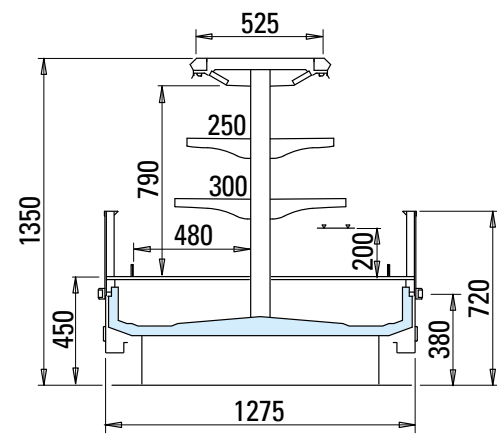

130 H135

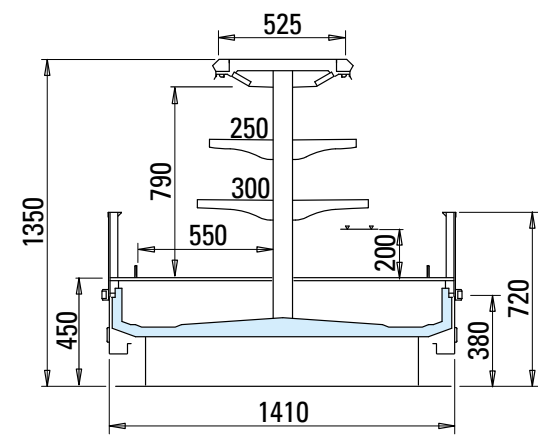

140 H135

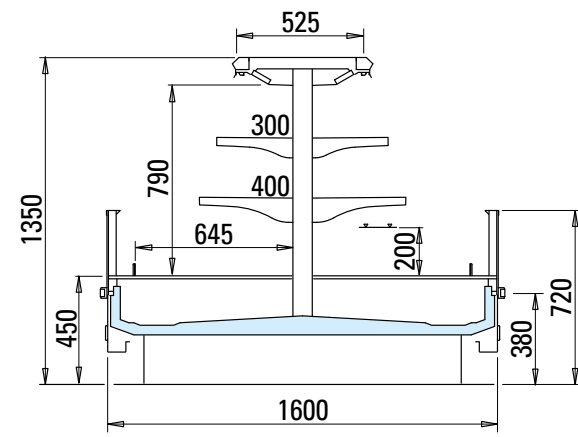

160 H135

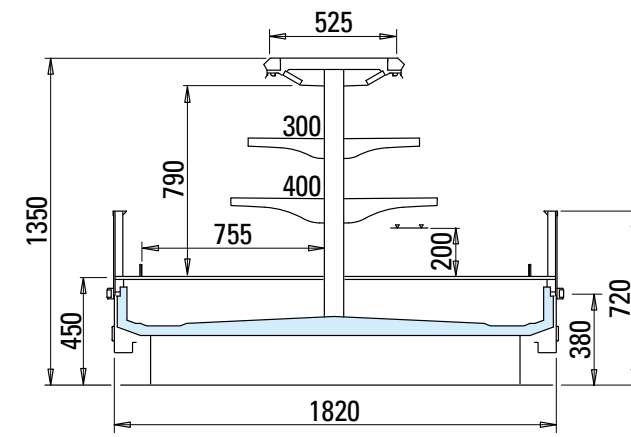

180 H135

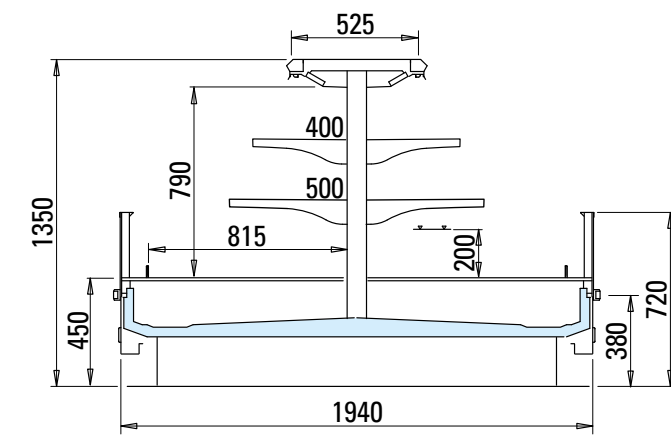

194 H135

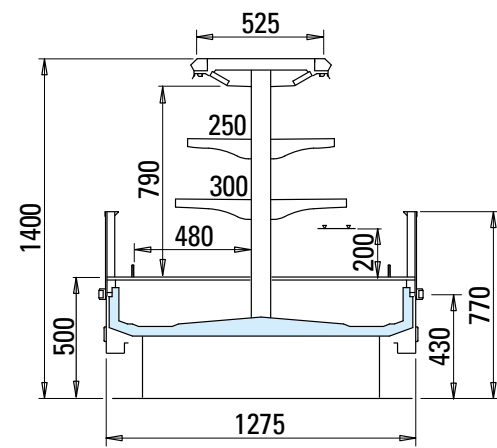

130 H140

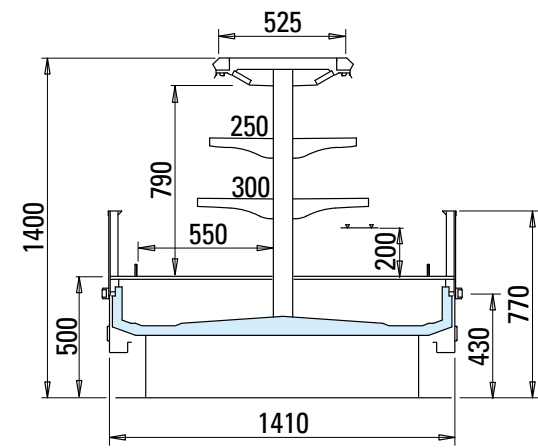

140 H140

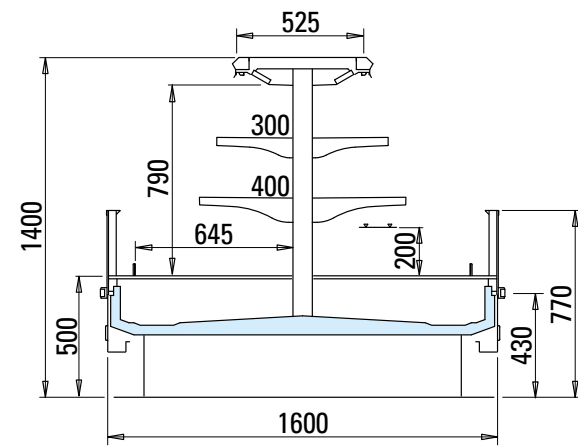

160 H140

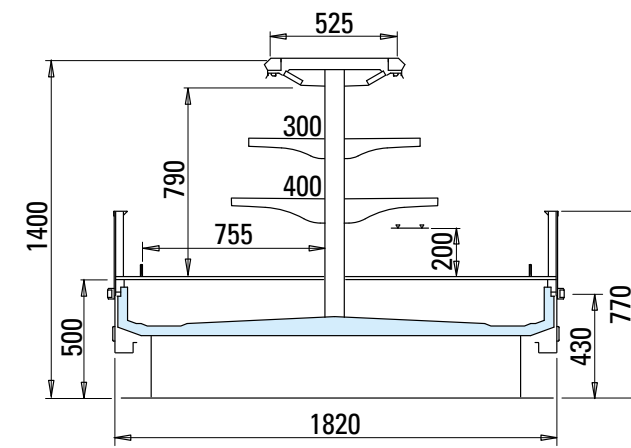

180 H140

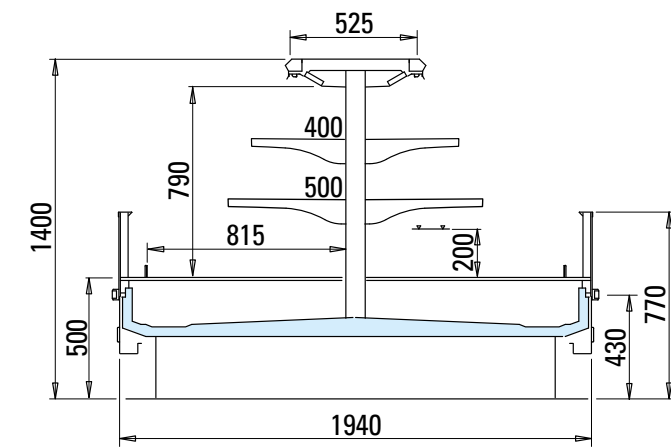

194 H140

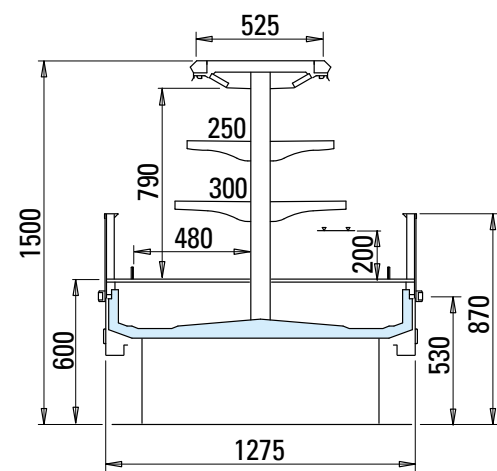

130 H150

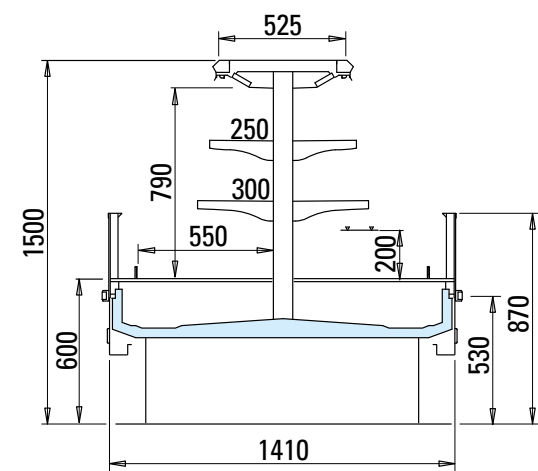

140 H150

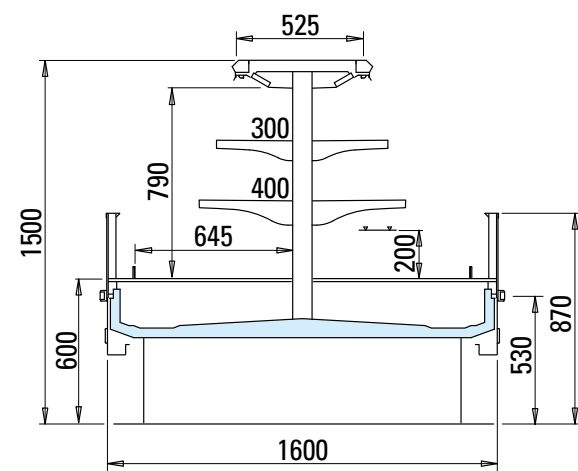

160 H150

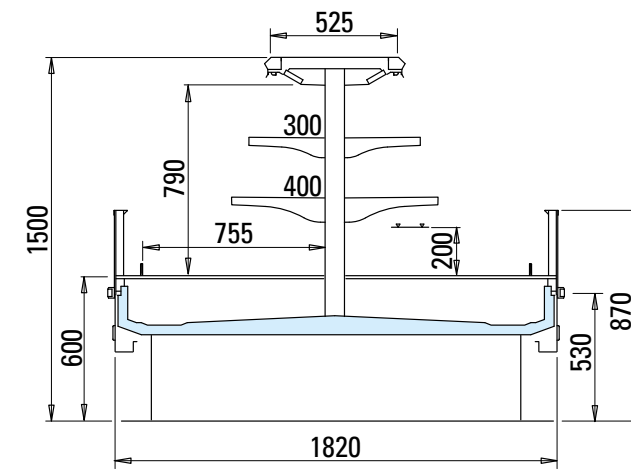

180 H150

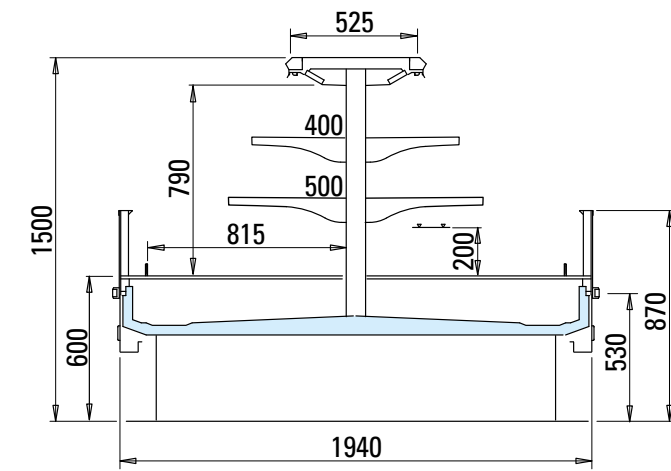

194 H150

VELDEN LX SVT-A-2 TN V TESTATA R

Length without side panels (mm)	1284				1419				1610				1832				1952			
Height (cm)	125	135	140	150	125	135	140	150	125	135	140	150	125	135	140	150	125	135	140	150
Temperature class	3M1	•							•				•							
	3M2	•							•				•							
Preservation temperature (°C)	0/+2	•							•				•							
	+2/+4	•							•				•							
Horizontal display area* (m²)	1,24	1,59			1,38	1,77			1,58	2,03			1,82	2,33			1,95	2,5		
Energy class**	A T G F				A T G F				A T G F				A T G F				A T G F			

*Value referred to illustrated configurations. **The energy class may vary depending on the product configuration.

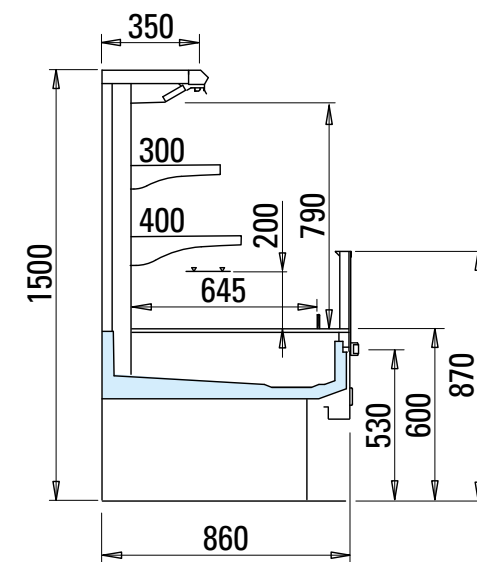
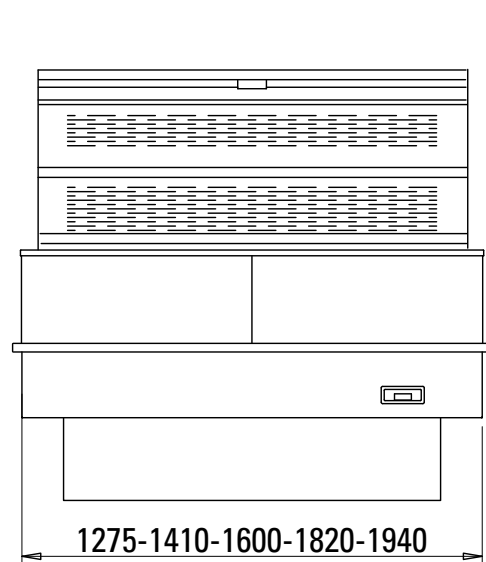

86 H150

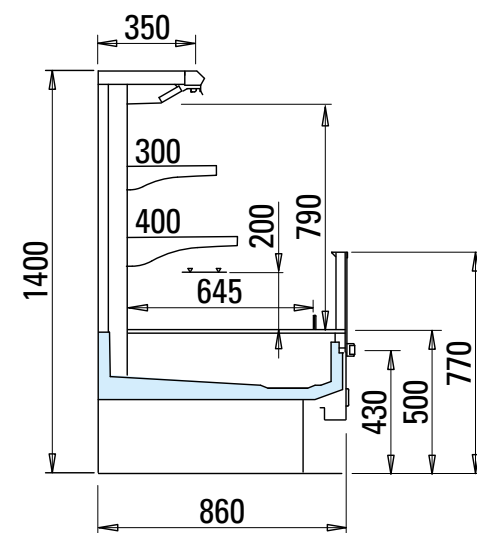

86 H140

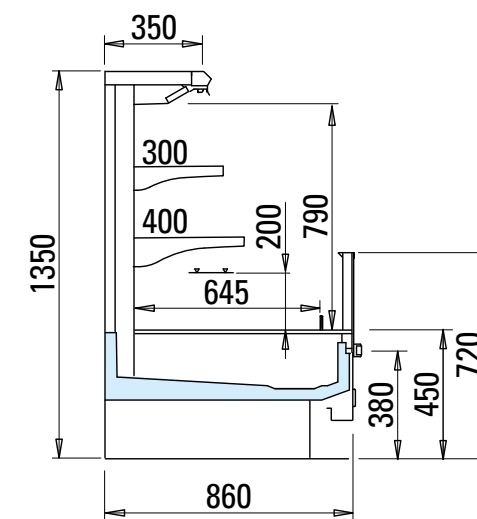

86 H135

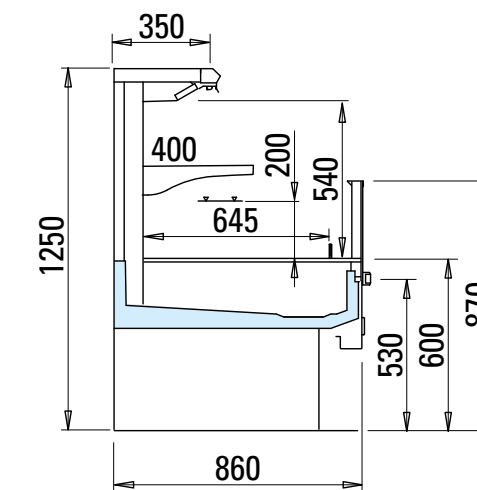

86 H125

ED. 00 - 21/04/2023

arneg[®]

WWW.ARNEG.COM



Arneg follows a policy of continuous improvement and reserves the right to update this document at any time without prior notice.